

So-called key haptic systems are used to test keys for the automotive and consumer sectors to record and evaluate their haptic torque curves.



To calibrate these systems, PANOVO tec has developed a force transfer standard measure THN 16 for cali-brating the entire haptic test system.

■ Backlash-free, friction-optimized guidance

The axial guidance of the tappet consists in backlash-free flexure bearings for minimizing friction and enhancing the system's repeatability. Tappet movement is also limited in the axial direction, also warranting an otherwise stiff mounting of the tappet.

■ Eccentric actuation

The THN 16's high tolerance to eccentric actuation is yet another advantage offered by the axial guidance. The measurement deviation for eccentric actuation is maximum $\pm 1\%$ for up to ± 1.0 mm deviation and maximum $\pm 2\%$ for ± 2.0 mm deviation.

■ Integrated overload protection

The standard measure has an integrated overload protection to prevent damage up to a force of 25 N.

Influence of eccentrical actuation to force F1

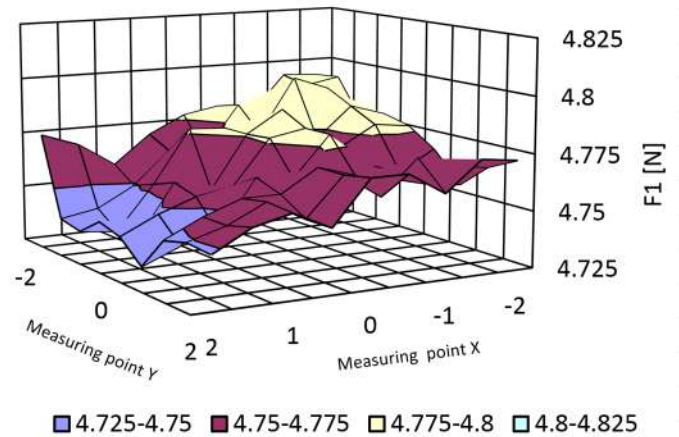

■ Eccentric actuation

The THN 16's high tolerance to eccentric actuation is yet another advantage offered by the axial guidance. The measurement deviation for eccentric actuation is maximum $\pm 1\%$ for up to ± 1.0 mm deviation and maximum $\pm 2\%$ for ± 2.0 mm deviation.

■ Technical data

Nominal force	5,0 N
Max. tol. Actuation force	$\pm 0,1$ N
Tol. radial offset (5x)	$\pm 0,05$ N
Max. tol. actuation force	25 N
Tol. radial offset of the test finger	2,5 mm
Max. force deviation for radial offset to 1.0 mm	1 %
Max. force deviation for radial offset to 2.0 mm	2 %
Nominal actuation speed	5 mm/s
Max. tol. actuation speed	100 mm/s
Service life in load cycles	10.000
Mass	26 \pm 1 g
Operation temperature	20 \pm 5 °C
Storage temperature	10 – 70 °C
Dimensions (SW x h)	16 x 25 mm

■ Engraved force curve

A defined, reproducible force curve is engraved in the THN 16 as standard measure.

The lower figure shows the den typical force curve for pushing and releasing.

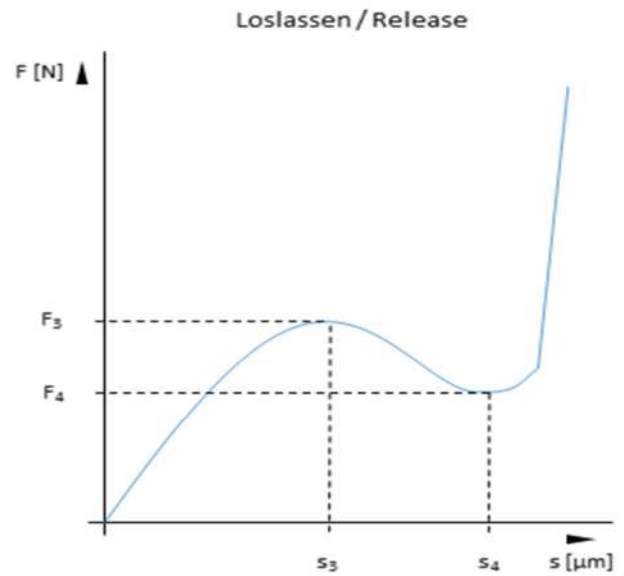
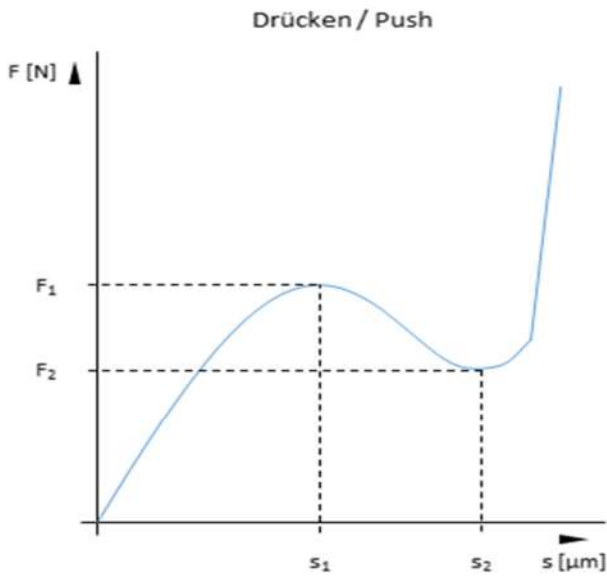

■ Longtime behavior

The stainless steel design protects the THN 16 from oxidation under the usual operating conditions prevailing in automation technology. The rating of

the mechanical components typical force curve for pushing and releasing. In the purely resilient range results in an almost unlimited service life.

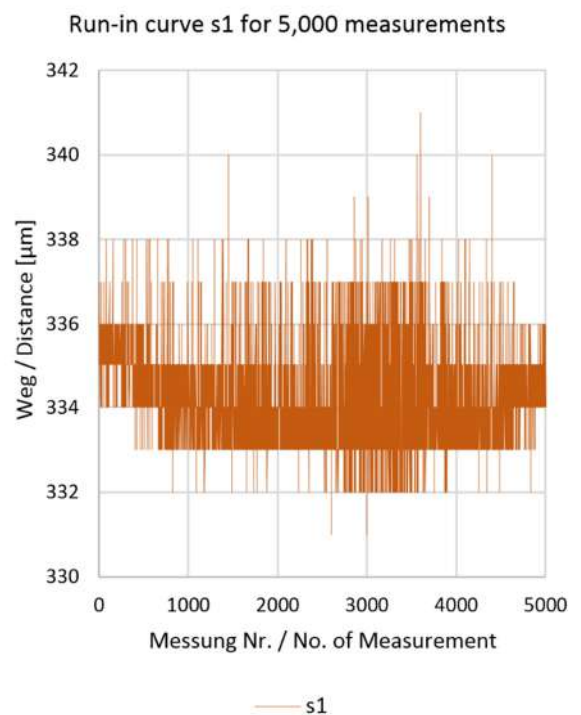
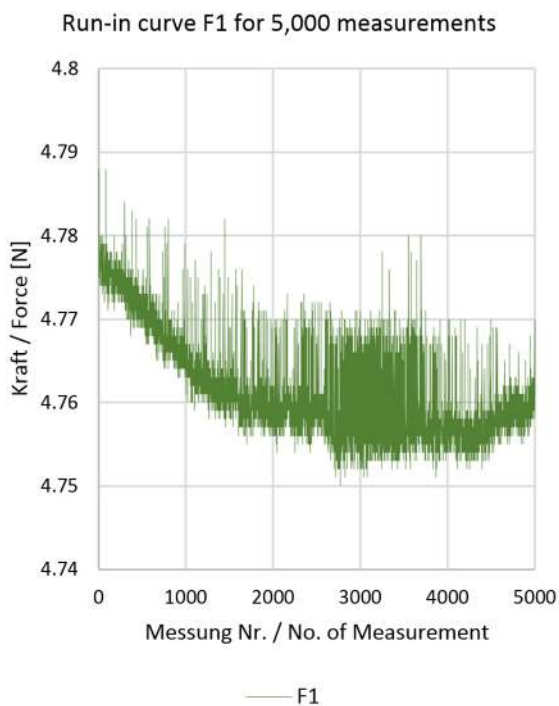

Each of our standard measures goes through a pre-delivery quality test with artificial aging consisting of several thousand pre-actuations.

It is thus possible to overcome an initial trend and to guarantee the calibrated force and distance values for more than 10,000 actuations.

typ. values of F1 und F2
for 5,000 measurements

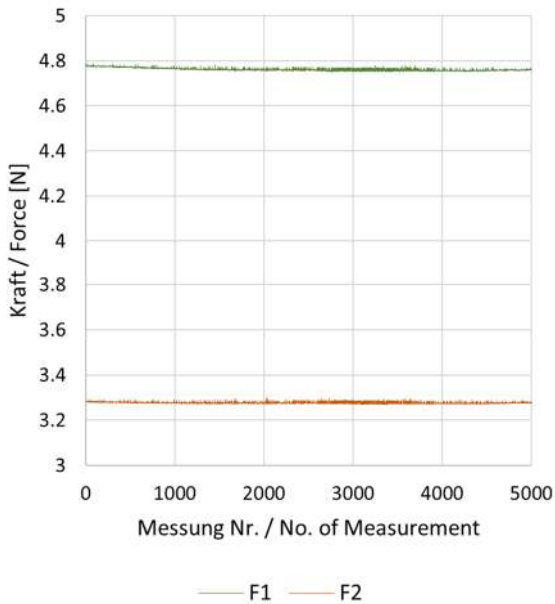

typ. values of s1 und s2
for 5,000 measurements

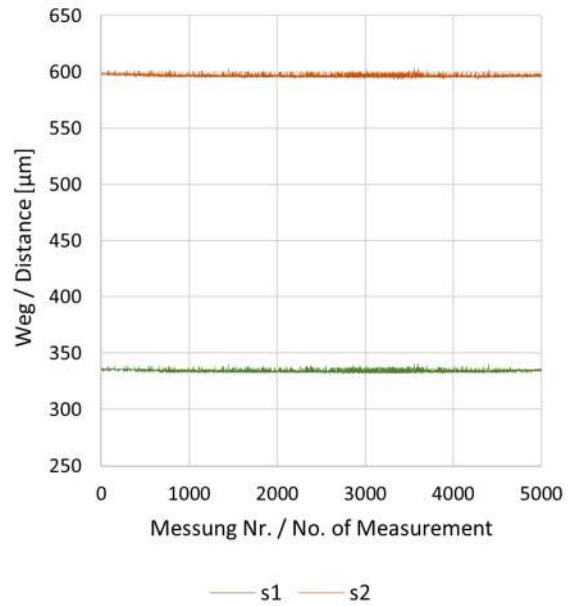

■ Dimensions and installation

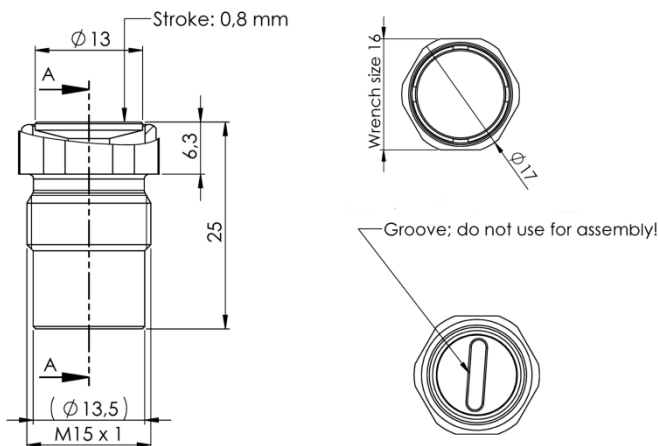

The THN 16 is screwed into an M15x1 fine-thread hole. The torque should not exceed 5.0 Nm.