

The measuring accuracy of a torque or rotary haptic measuring system depends on the torsion-resistant coupling between test object and test unit and the lowest possible mass moment of inertia in the whole measuring unit.



■ Technical data

Ø gripping range	15 ... 60 mm
Transferable torque (standard)	> 70 mNm
Mass	50 ± 5 g
Mass moment of inertia open gripper	130 ± 10 gcm ²
Mass moment of inertia closed gripper	75 ± 5 gcm ²
Nominal angular velocity	60 °/s Max. zul
Max. tol. speed	500 rpm
Operation temperature	10 ... 50 °C
Storage temperature	10 ... 70 °C
Dimensions (L x B x H)	See drawing
Standard shaft diameter	6 mm

■ Dimensions

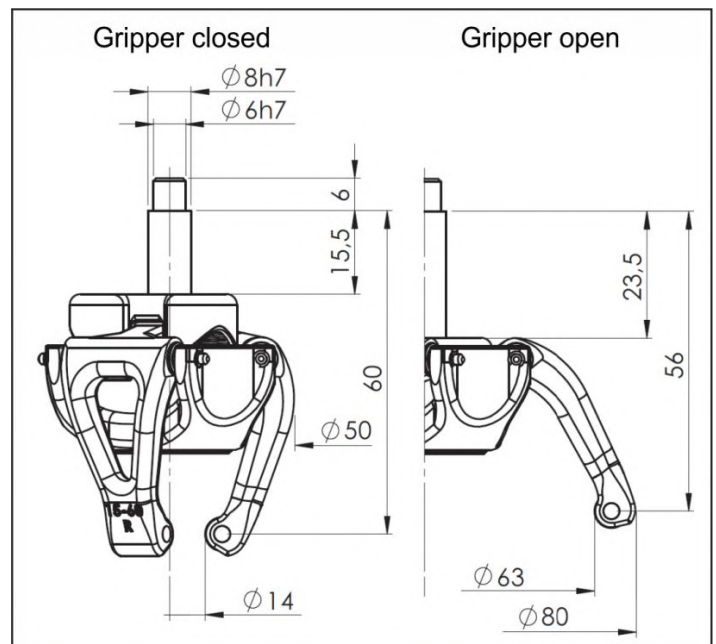

The rotary haptic grippers in the DHG3 series have been specially developed for use in rotary haptic measuring systems. They have been optimized with regard to the mass moment of inertia and torsion resistance, while their high reliability and torsion resistance have been demonstrated in many applications.

Rotary haptic grippers in the DHG3 series warrant reliable transfer of the torque being measured from the test object to the measuring system and also permit fast changing of the test object. With a gripping range of 15 to 60 mm in the standard version (customized versions on request), one single gripper in the DHG3 series covers practically the whole range of rotary actuators found in control units and in vehicle interiors. Special highly wear-proof fingertips warrant a long service life, even for ribbed metallic surfaces.

■ Transferable torque

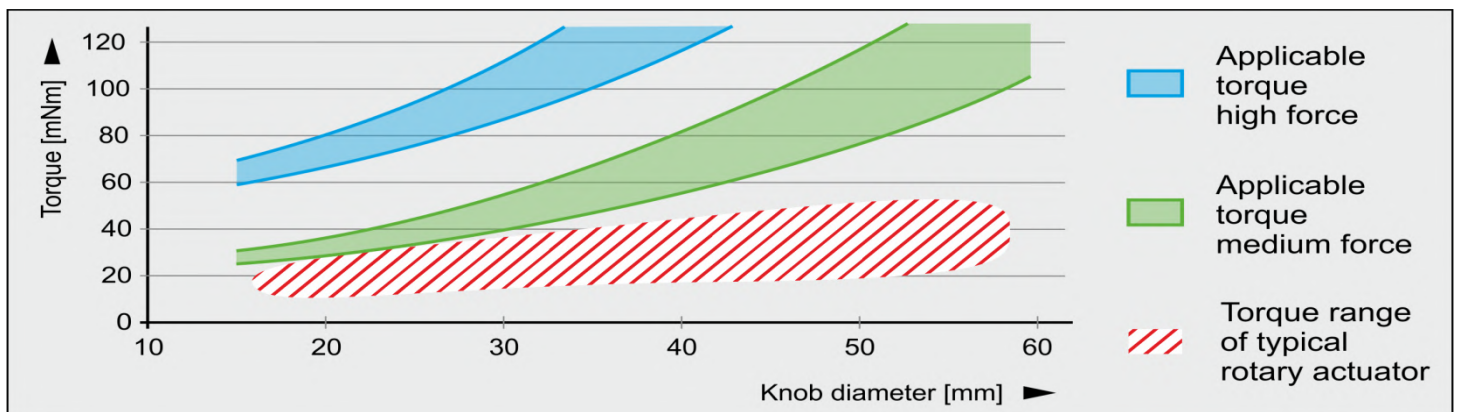

■ Fingertip geometry

In the standard version, the DHG3 series is available with two different fingertips; individual fingertip geometries are available on request.

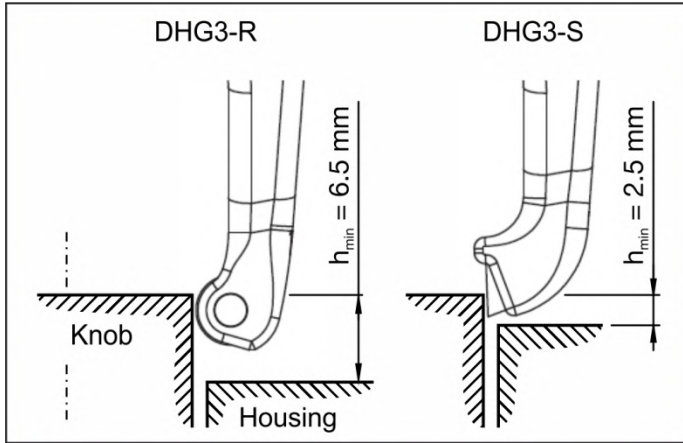

DHG3-R

Round universal tip, gripping range 15 - 60 mm = gripping distance > 45mm, suitable for most applications.

DHG3-S

Pointed finger for use in restricted space. The geometry of the gripper fingers reduces the effective gripper distance to 15 mm within the gripping range of 15 - 60 mm. Please state the required gripping range in your order.

■ Order Code

